

STEM & SEAT DESIGN FEATURE

STEM DESIGN

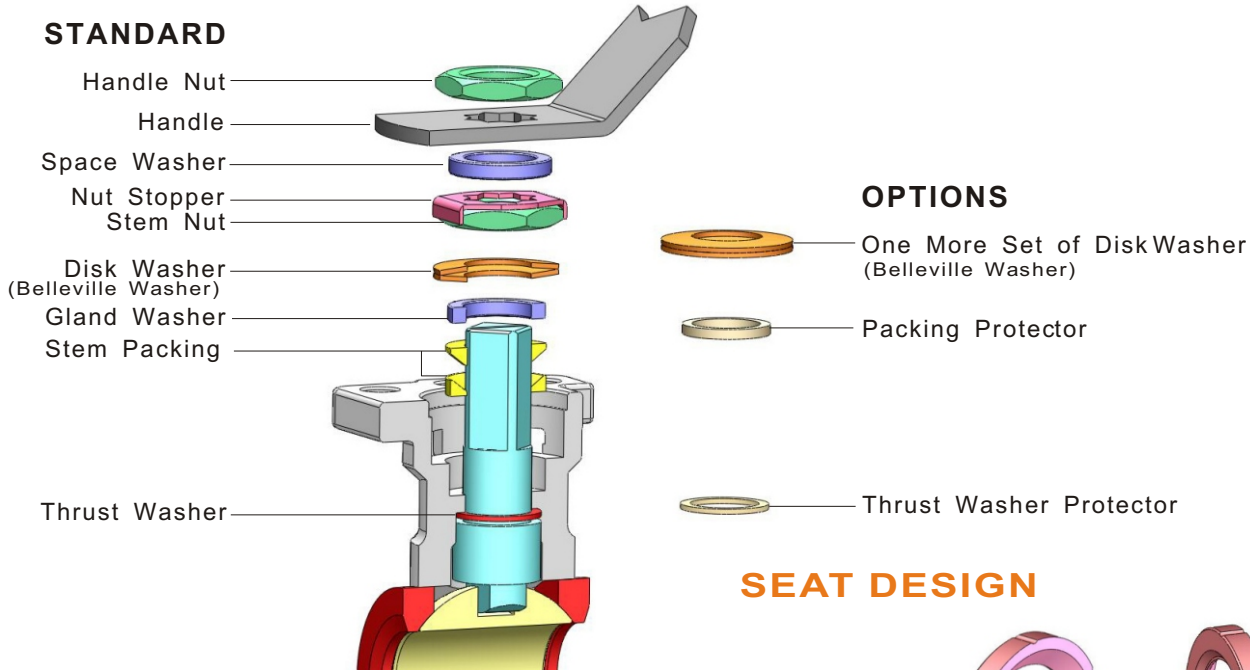

SEAT DESIGN

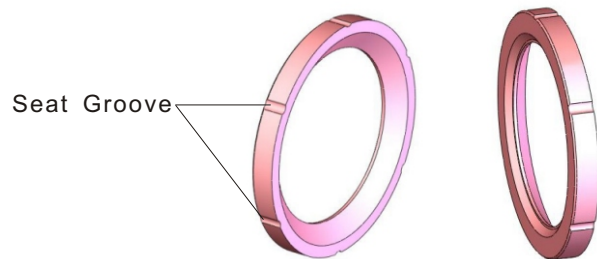

ZIPSON'S standard stem design for ISO direct mount type valve, 201D, 302F, 305D, 306D, 107S, 207S are all with SS301 disk washer (belleville washer). This smart design will allow the stem to adjust itself, and increase the lifetime of cycle operator. For high temperature operation, 17-4 material belleville washer are available as required.

2 to 3 pc/set stem packing was pressed by the nut & disk washer to expand the packing for sealing well. All Zipson's stem were designed for blow-out proof for safety.

The complete stem set were locked by the saddle shape nut stopper. This will ensure the stem set get tight after thousands of operation.

Some options are available for critical usage on stem design. One more set of disk washer, PEEK packing protector, PEEK thrust washer protector are set for prolonging the cycle operation lifetime. For fire safe design or high temperature operation, Graphite stem packing will perform very well. Anti-static device are available when asked.

Zipson's seat were designed with seat groove for releasing the pressure and protecting the seats from deforming. This design will reduce the torque when operate the valve as well.

Fugitive emission bonnet is for option as the media is dangerous or for safety.

Many kinds of materials for soft kits are for option. Standard pure PTFE suite most of the situation. TFM1600 (TFM) is good for steam at 160°C, or TFM4215 (TFM+25% Carbon) suit 200°C steam media. PEEK (450G) is good at high temperature & high pressure application. Reinforced PEEK+Carbon (450CA30) is good at higher temperature usage than pure PEEK, up to 2800 psi at 275°C)

