

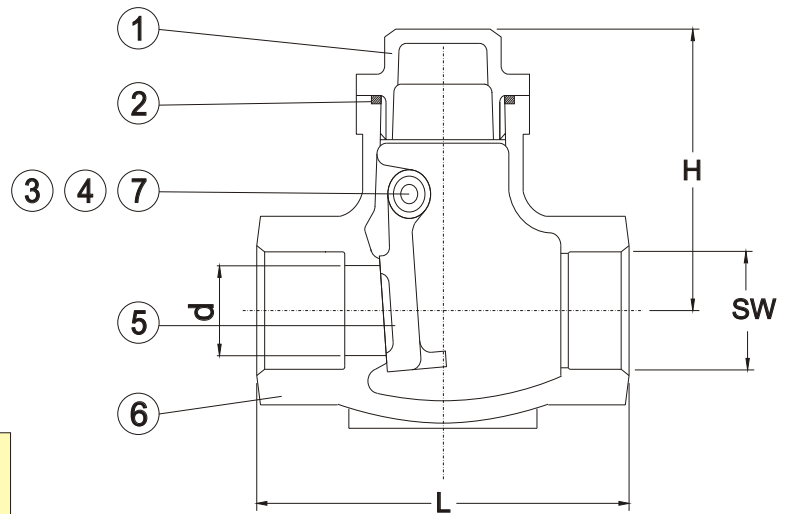

SPECIFICATION

- * Body & end caps quality investment casting
- * 200 WOG working pressure
- * Size range: 1/4" to 3"
- * Non-rising stem, non-rising handwheel



DIMENSIONS (mm)

SIZE	L	H	∅SW	d
1/4"	58.0	41.0	-	11.0
3/8"	58.0	41.0	-	12.0
1/2"	66.0	45.0	21.8	15.0
3/4"	81.0	54.0	27.1	20.0
1"	91.0	59.0	33.8	25.0
1-1/4"	106.5	69.0	42.6	31.0
1-1/2"	121.0	75.5	48.7	37.0
2"	142.0	81.0	61.2	48.0
2-1/2"	159.0	90.0	73.8	63.0
3"	190.0	98.0	89.8	75.0

PRESSURE/ TEMPERATURE (BODY)

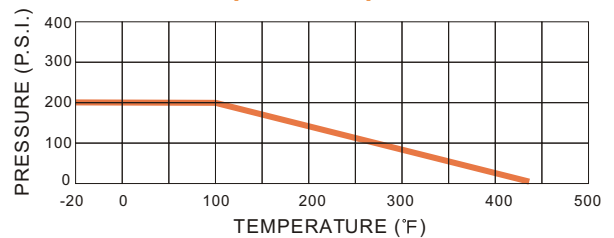

MATERIALS LIST

ITEM	PART NAME	MATERIALS
1	COVER	CF8M
2	GASKET	PTFE
3	PIN	SS 316
4	PLUG	SS 316
5	DISC	CF8M
6	BODY	CF8M
7	GASKET	PTFE