



ZIPSON'S 305D, 3-piece high performance metal seated ball valve with ISO direct mounting pad is designed for use in high temperature, abrasive, and high pressure media in power generation, petrochemical industries, mining industries, and pulp & paper ones.

To compare the economic valve in the market, Zipson make valve structure & wall thickness totally follow ASME B16.34 standard on Class900 construction. The exact structure make safe in the high performance application.

The standard material for metal seat & ball is Co element (known as Stellite). The Co based material is good at hardness, corrosion resistance and stable under high temperature.

The Zipson patent unique split seat design is perfect to seal the leakage from & over the seat area to make Zipson's metal seated valves meet at least Class V leakage class.

305D metal seated type is bi-directional design to simplify the plumbing works.

SPECIFICATION

- * Body & end caps quality investment casting
- * Valve construction & thickness follow ANSIB16.34
- * Inconel spring design provide better sealing function
- * Class 900 construction design
- * Bi-directional design (**Zipson patented seat design**)
- * ISO 5211 direct mounting pad
- * Adjustable stem packing
- * Live loaded & blow-out proof stem design
- * Anti-static device
- * End type: Thread/ SW/ BW/ Flange

OPTION

- * Fire safe design
- * Heating Jacket
- * V-ball for flow control
- * Automation application
- * Cryogenic & Fugitive emission stem extension
- * Special Alloy on body/ end/ ball/ stem

METAL SEATED VALVE DESIGN FEATURES

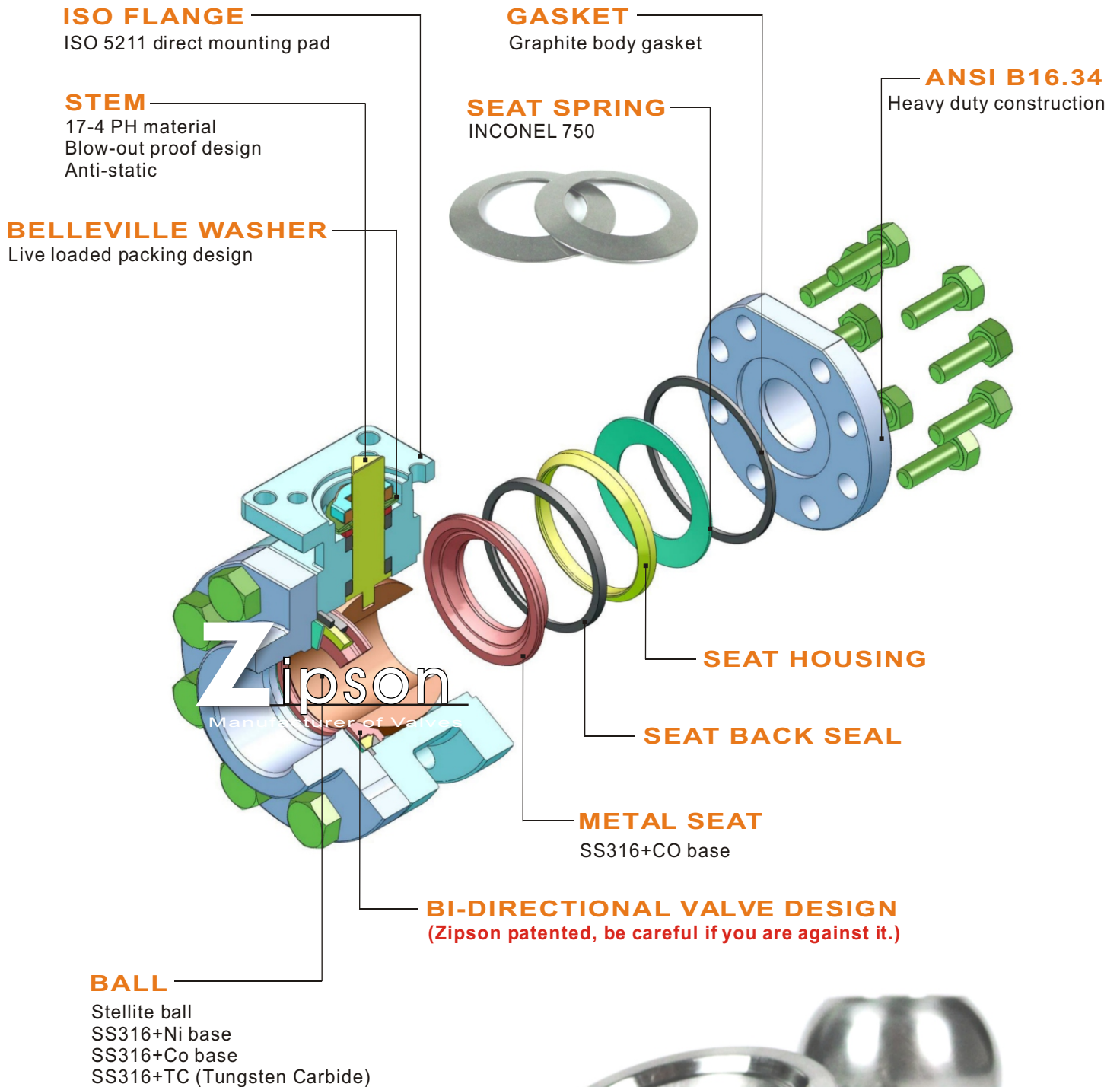

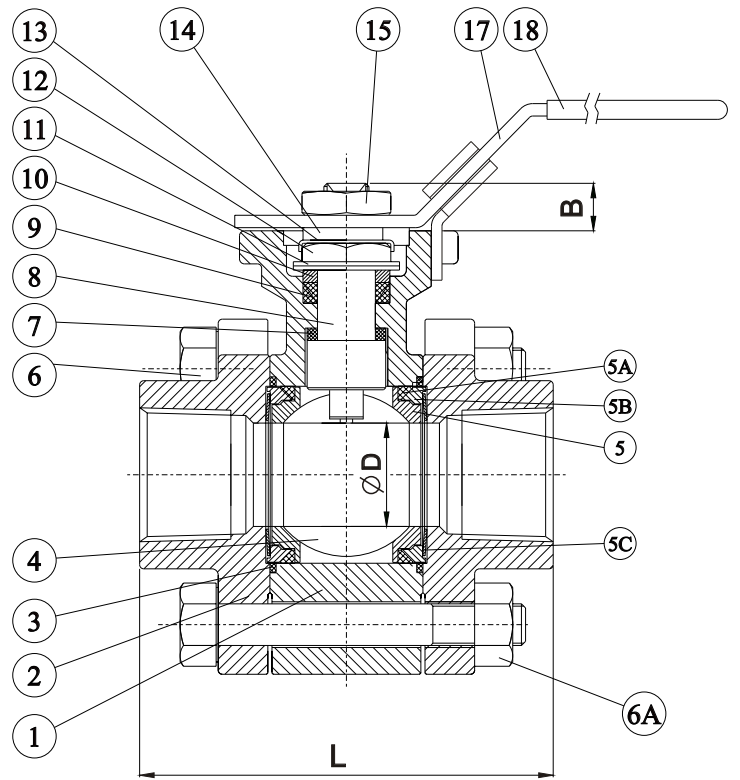
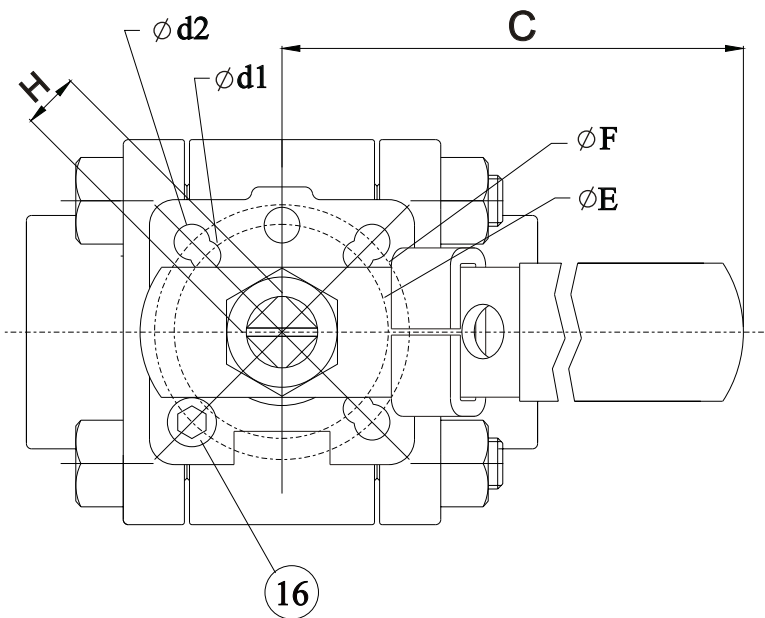

MATERIALS LIST

ITEM	PART NAME	MATERIALS
1	BODY	CF8M
2	END	CF8M
3	GASKET	GRAPHITE
4	BALL	Co.Base/ Ni Base
5	SEAT	SS316+STELLITE
5A	SEAT SEAL	GRAPHITE
5B	SEAT HOUSING	SS316
5C	DISK WASHER	INCONEL
6	BOLT	SS 304
6A	NUT	SS304
7	STEM RING	GRAPHITE
8	STEM	SS 316/ 17-4
9	STEM SEAL	GRAPHITE
10	BEARING	SS 304
11	DISK WASHER	SS 301
12	STEM NUT	SS 304
13	NUT STOPPER	SS 304
14	WASHER	SS 304
15	HANDLE NUT	SS 304
16	STOP PIN SET	SS 304
17	HANDLE	SS 304
18	SLEEVE	PLASTISOL

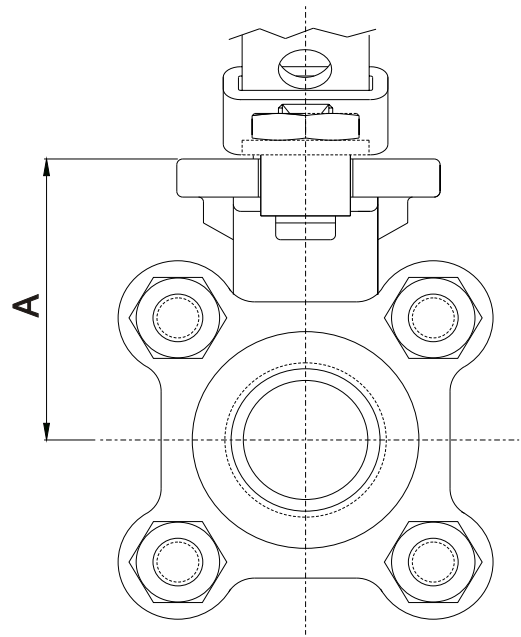

DIMENSIONS (mm)

SIZE	A	B	C	D	d1	d2	E	F	H	L	SW		BW(40#)		BW(80#)	
											S	T	OD	ID	OD	ID
1/4"	46	9.5	130	11	6.0	6.0	36	42	9	66.5	14.2	11.1	14.0	9.2	14.0	7.5
3/8"	46	9.5	130	12.5	6.0	6.0	36	42	9	66.5	17.5	11.1	17.0	12.7	17.0	10.8
1/2"	48	9.5	130	15	6.0	6.0	36	42	9	70	21.8	12.7	21.3	15.9	21.3	13.8
3/4"	53	12	155	20	6.0	6.0	42	50	11	92	27.1	14.3	26.7	20.8	26.7	18.9
1"	59	12	155	25	6.0	7.0	42	50	11	105	33.8	15.9	33.3	26.6	33.3	24.3
1-1/4"	62	14.5	205	32	7.0	9.2	50	70	14	111	42.5	17.5	42.2	35.1	42.2	32.5
1-1/2"	70	14.5	205	38	7.0	9.2	50	70	14	124	48.7	18.3	48.5	40.8	48.5	38.1
2"	90	19	300	50	9.2	11.4	70	102	17	150	61.1	21.3	60.5	52.4	60.5	49.3

PRESSURE/ TEMPERATURE CHART

